



## Low Noise/Low Power/SPI Bus

# X9400

## Quad Digitally Controlled Potentiometers (XDCP™)

### FEATURES

- Four potentiometers per package
- 64 resistor taps
- SPI serial interface for write, read, and transfer operations of the potentiometer
- Wiper resistance, 40Ω typical at 5V.
- Four non-volatile data registers for each potentiometer
- Non-volatile storage of multiple wiper position
- Power on recall. Loads saved wiper position on power up.
- Standby current < 1μA max
- System  $V_{CC}$ : 2.7V to 5.5V operation
- Analog  $V^+/V^-$ : -5V to +5V
- 10KΩ, 2.5KΩ End to end resistance
- 100 yr. data retention
- Endurance: 100,000 data changes per bit per register
- Low power CMOS
- 24-lead SOIC, 24-lead TSSOP, and 24-lead CSP (Chip Scale Package) packages

### DESCRIPTION

The X9400 integrates four digitally controlled potentiometers (XDCPs) on a monolithic CMOS integrated circuit.

The digitally controlled potentiometer is implemented using 63 resistive elements in a series array. Between each element are tap points connected to the wiper terminal through switches. The position of the wiper on the array is controlled by the user through the SPI serial bus interface. Each potentiometer has associated with it a volatile Wiper Counter Register (WCR) and four nonvolatile Data Registers (DR0-3) that can be directly written to and read by the user. The contents of the WCR controls the position of the wiper on the resistor array through the switches. Power up recalls the contents of DR0 to the WCR.

The XDCP can be used as a three-terminal potentiometer or as a two-terminal variable resistor in a wide variety of applications including control, parameter adjustments, and signal processing.

### BLOCK DIAGRAM

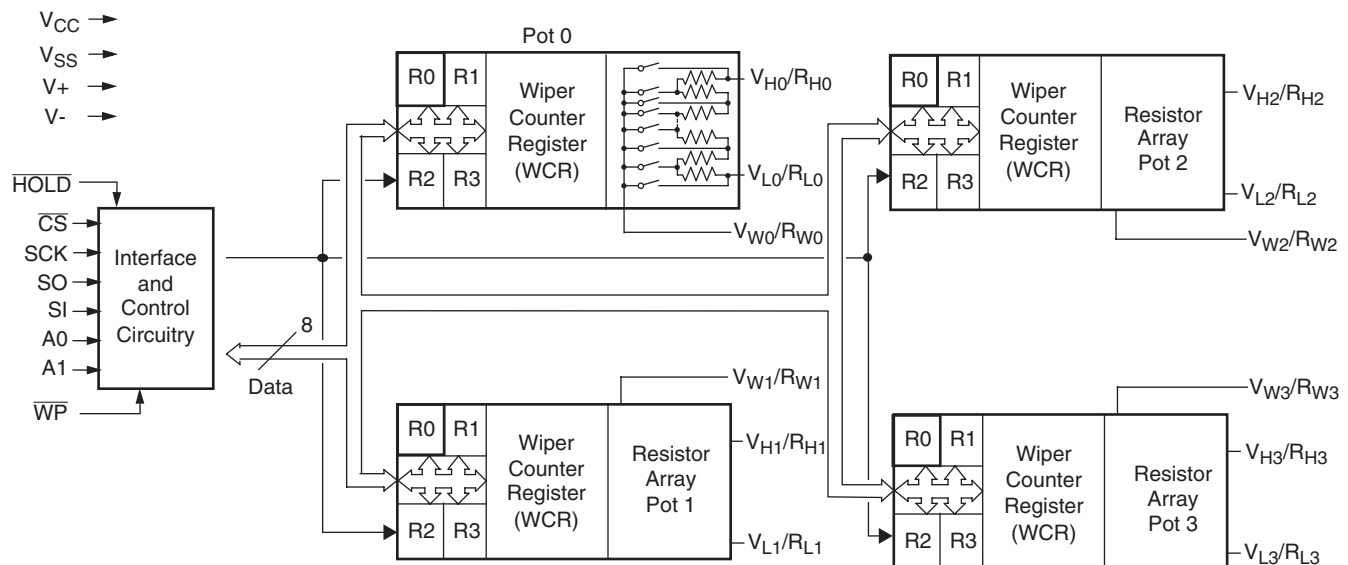

# X9400

## PIN DESCRIPTIONS

### Host Interface Pins

#### Serial Output (SO)

SO is a push/pull serial data output pin. During a read cycle, data is shifted out on this pin. Data is clocked out by the falling edge of the serial clock.

#### Serial Input

SI is the serial data input pin. All opcodes, byte addresses and data to be written to the pots and pot registers are input on this pin. Data is latched by the rising edge of the serial clock.

#### Serial Clock (SCK)

The SCK input is used to clock data into and out of the X9400.

#### Chip Select ( $\overline{CS}$ )

When  $\overline{CS}$  is HIGH, the X9400 is deselected and the SO pin is at high impedance, and (unless an internal write cycle is underway) the device will be in the standby state.  $\overline{CS}$  LOW enables the X9400, placing it in the active power mode. It should be noted that after a power-up, a HIGH to LOW transition on  $\overline{CS}$  is required prior to the start of any operation.

#### Hold ( $\overline{HOLD}$ )

$\overline{HOLD}$  is used in conjunction with the  $\overline{CS}$  pin to select the device. Once the part is selected and a serial sequence is underway,  $\overline{HOLD}$  may be used to pause the serial communication with the controller without

resetting the serial sequence. To pause,  $\overline{HOLD}$  must be brought LOW while SCK is LOW. To resume communication,  $\overline{HOLD}$  is brought HIGH, again while SCK is LOW. If the pause feature is not used,  $\overline{HOLD}$  should be held HIGH at all times.

#### Device Address ( $A_0$ - $A_1$ )

The address inputs are used to set the least significant 2 bits of the 8-bit slave address. A match in the slave address serial data stream must be made with the address input in order to initiate communication with the X9400. A maximum of 4 devices may occupy the SPI serial bus.

#### Potentiometer Pins

#### $V_H/R_H$ ( $V_{H0}/R_{H0}$ - $V_{H3}/R_{H3}$ ), $V_L/R_L$ ( $V_{L0}/R_{L0}$ - $V_{L3}/R_{L3}$ )

The  $V_H/R_H$  and  $V_L/R_L$  inputs are equivalent to the terminal connections on either end of a mechanical potentiometer.

#### $V_W/R_W$ ( $V_{W0}/R_{W0}$ - $V_{W3}/R_{W3}$ )

The wiper outputs are equivalent to the wiper output of a mechanical potentiometer.

#### Hardware Write Protect Input ( $\overline{WP}$ )

The  $\overline{WP}$  pin when LOW prevents nonvolatile writes to the Data Registers.

#### Analog Supplies ( $V+$ , $V-$ )

The analog Supplies  $V+$ ,  $V-$  are the supply voltages for the XDCP analog section.

## PIN CONFIGURATION

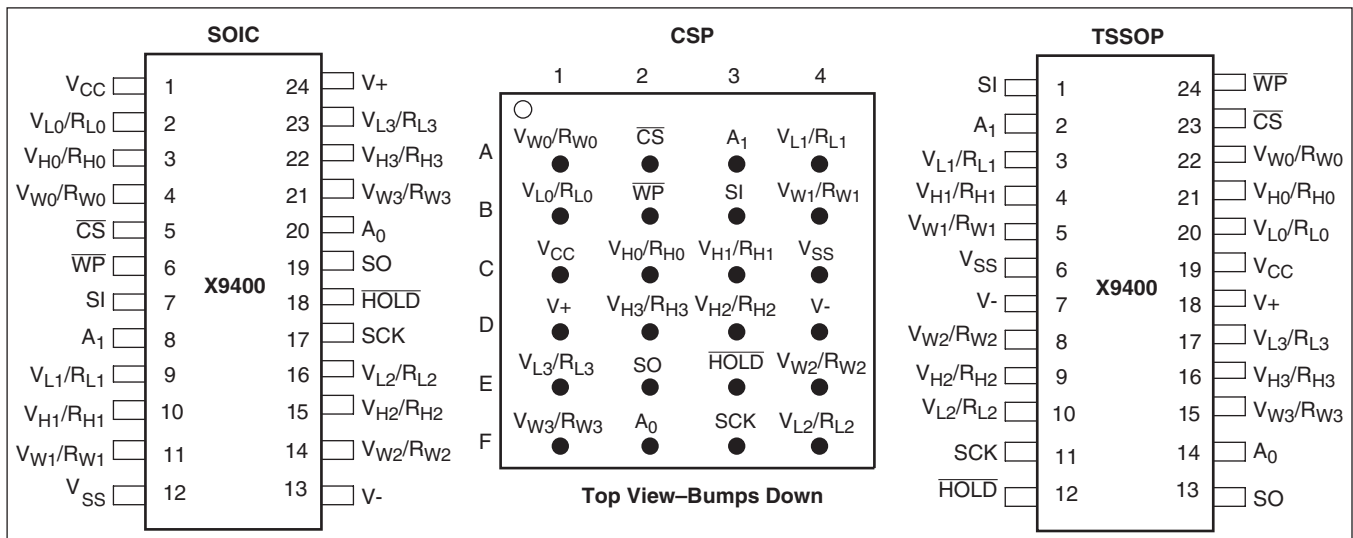

# X9400

## PIN NAMES

Symbol	Description
SCK	Serial Clock
SI, SO	Serial Data
A <sub>0</sub> -A <sub>1</sub>	Device Address
V <sub>H0</sub> /R <sub>H0</sub> -V <sub>H3</sub> /R <sub>H3</sub> , V <sub>L0</sub> /R <sub>L0</sub> -V <sub>L3</sub> /R <sub>L3</sub>	Potentiometer Pins (terminal equivalent)
V <sub>W0</sub> /R <sub>W0</sub> -V <sub>W1</sub> /R <sub>W1</sub>	Potentiometer Pins (wiper equivalent)
$\overline{WP}$	Hardware Write Protection
V <sub>CC</sub>	System Supply Voltage
V <sub>SS</sub>	System Ground
NC	No Connection

## DEVICE DESCRIPTION

The X9400 is a highly integrated microcircuit incorporating four resistor arrays and their associated registers and counters and the serial interface logic providing direct communication between the host and the XDCP potentiometers.

### Serial Interface

The X9400 supports the SPI interface hardware conventions. The device is accessed via the SI input with data clocked in on the rising SCK.  $\overline{CS}$  must be LOW and the  $\overline{HOLD}$  and  $\overline{WP}$  pins must be HIGH during the entire operation.

The SO and SI pins can be connected together, since they have three state outputs. This can help to reduce system pin count.

### Array Description

The X9400 is comprised of four resistor arrays. Each array contains 63 discrete resistive segments that are connected in series. The physical ends of each array are equivalent to the fixed terminals of a mechanical potentiometer (V<sub>H</sub>/R<sub>H</sub> and V<sub>L</sub>/R<sub>L</sub> inputs).

At both ends of each array and between each resistor segment is a CMOS switch connected to the wiper (V<sub>W</sub>/R<sub>W</sub>) output. Within each individual array only one switch may be turned on at a time.

These switches are controlled by a wiper counter register (WCR). The six bits of the WCR are decoded to select, and enable, one of sixty-four switches.

### Wiper Counter Register (WCR)

The X9400 contains four Wiper Counter Registers, one for each XDCP potentiometer. The WCR is equivalent to a serial-in, parallel-out register/counter with its outputs decoded to select one of sixty-four switches along its resistor array. The contents of the WCR can be altered in four ways: it may be written directly by the host via the write Wiper Counter Register instruction (serial load); it may be written indirectly by transferring the contents of one of four associated data registers via the XFR Data Register or global XFR data register instructions (parallel load); it can be modified one step at a time by the increment/decrement instruction. Finally, it is loaded with the contents of its Data Register zero (DR0) upon power-up.

The Wiper Counter Register is a volatile register; that is, its contents are lost when the X9400 is powered-down. Although the register is automatically loaded with the value in DR0 upon power-up, this may be different from the value present at power-down.

### Data Registers

Each potentiometer has four 6-bit nonvolatile Data Registers. These can be read or written directly by the host. Data can also be transferred between any of the four Data Registers and the associated Wiper Counter Register. All operations changing data in one of the data registers is a nonvolatile operation and will take a maximum of 10ms.

If the application does not require storage of multiple settings for the potentiometer, the Data Registers can be used as regular memory locations for system parameters or user preference data.

### Data Register Detail

(MSB)				(LSB)	
D5	D4	D3	D2	D1	D0
NV	NV	NV	NV	NV	NV

# X9400

**Figure 1. Detailed Potentiometer Block Diagram**

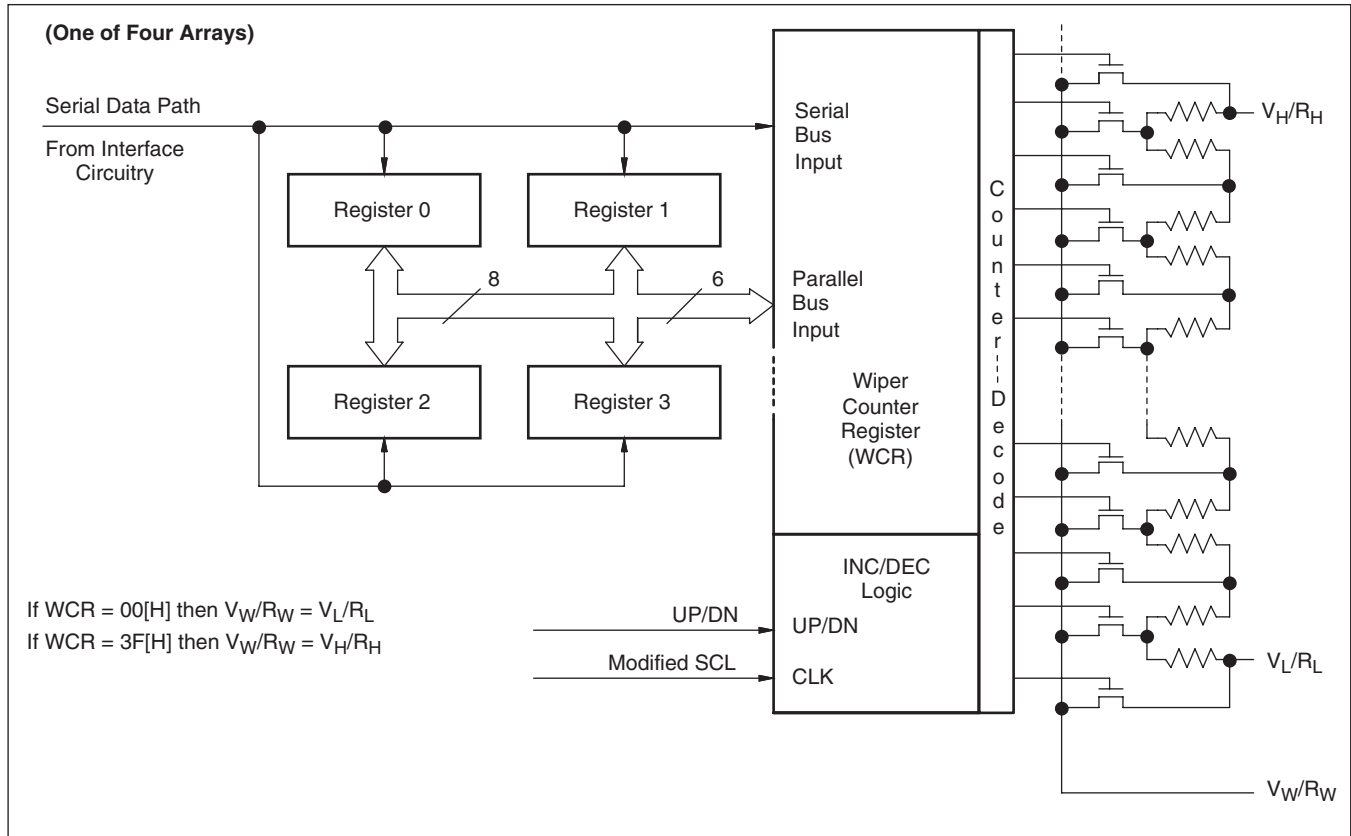

## Write in Process

The contents of the Data Registers are saved to nonvolatile memory when the  $\overline{CS}$  pin goes from LOW to HIGH after a complete write sequence is received by the device. The progress of this internal write operation can be monitored by a write in process bit (WIP). The WIP bit is read with a read status command.

## INSTRUCTIONS

### Identification (ID) Byte

The first byte sent to the X9400 from the host, following a  $\overline{CS}$  going HIGH to LOW, is called the Identification byte. The most significant four bits of the slave address are a device type identifier, for the X9400 this is fixed as 0101[B] (refer to Figure 2).

The two least significant bits in the ID byte select one of four devices on the bus. The physical device address is defined by the state of the  $A_0$ - $A_1$  input pins. The X9400 compares the serial data stream with the address input state; a successful compare of both address bits is

required for the X9400 to successfully continue the command sequence. The  $A_0$ - $A_1$  inputs can be actively driven by CMOS input signals or tied to  $V_{CC}$  or  $V_{SS}$ .

The remaining two bits in the slave byte must be set to 0.

**Figure 2. Identification Byte Format**

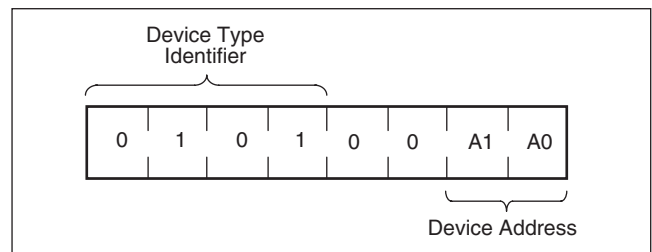

### Instruction Byte

The next byte sent to the X9400 contains the instruction and register pointer information. The four most significant bits are the instruction. The next four bits point to one of the four pots and, when applicable, they point to one of four associated registers. The format is shown below in Figure 3.

**Figure 3. Instruction Byte Format**

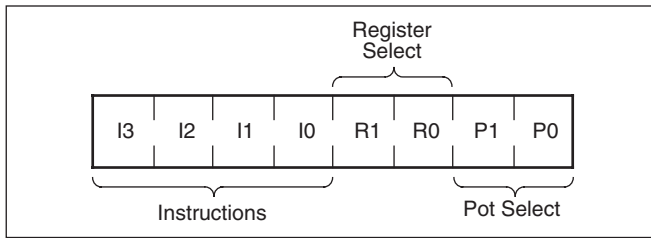

The four high order bits of the instruction byte specify the operation. The next two bits ( $R_1$  and  $R_0$ ) select one of the four registers that is to be acted upon when a register oriented instruction is issued. The last two bits ( $P_1$  and  $P_0$ ) selects which one of the four potentiometers is to be affected by the instruction.

Four of the ten instructions are two bytes in length and end with the transmission of the instruction byte. These instructions are:

- XFR Data Register to Wiper Counter Register—This transfers the contents of one specified Data Register to the associated Wiper Counter Register.
- XFR Wiper Counter Register to Data Register —This transfers the contents of the specified Wiper Counter Register to the specified associated Data Register.
- Global XFR Data Register to Wiper Counter Register — This transfers the contents of all specified Data Registers to the associated Wiper Counter Registers.
- Global XFR Wiper Counter Register to Data Register — This transfers the contents of all Wiper Counter Registers to the specified associated Data Registers.

The basic sequence of the two byte instructions is illustrated in Figure 4. These two-byte instructions exchange data between the WCR and one of the data registers. A transfer from a Data Register to a WCR is essentially a write to a static RAM, with the static RAM controlling the wiper position. The response of the wiper to this action will be delayed by  $t_{WRL}$ . A transfer from the WCR (current wiper position), to a data register is a write to nonvolatile memory and takes a minimum of

$t_{WR}$  to complete. The transfer can occur between one of the four potentiometers and one of its associated registers; or it may occur globally, where the transfer occurs between all potentiometers and one associated register.

Five instructions require a three-byte sequence to complete. These instructions transfer data between the host and the X9400; either between the host and one of the data registers or directly between the host and the Wiper Counter Register. These instructions are:

- Read Wiper Counter Register—read the current wiper position of the selected pot,
- Write Wiper Counter Register—change current wiper position of the selected pot,
- Read Data Register—read the contents of the selected data register;
- Write Data Register—write a new value to the selected data register.
- Read Status—This command returns the contents of the WIP bit which indicates if the internal write cycle is in progress.

The sequence of these operations is shown in Figure 5 and Figure 6.

The final command is Increment/Decrement. It is different from the other commands, because it's length is indeterminate. Once the command is issued, the master can clock the selected wiper up and/or down in one resistor segment steps; thereby, providing a fine tuning capability to the host. For each SCK clock pulse ( $t_{HIGH}$ ) while SI is HIGH, the selected wiper will move one resistor segment towards the  $V_H/R_H$  terminal. Similarly, for each SCK clock pulse while SI is LOW, the selected wiper will move one resistor segment towards the  $V_L/R_L$  terminal. A detailed illustration of the sequence and timing for this operation are shown in Figure 7 and Figure 8.

Figure 4. Two-Byte Instruction Sequence

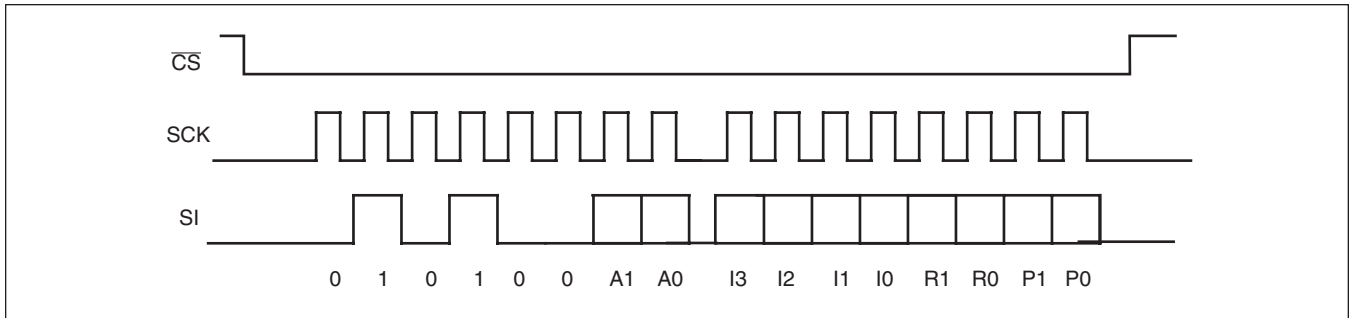

Figure 5. Three-Byte Instruction Sequence (Write)

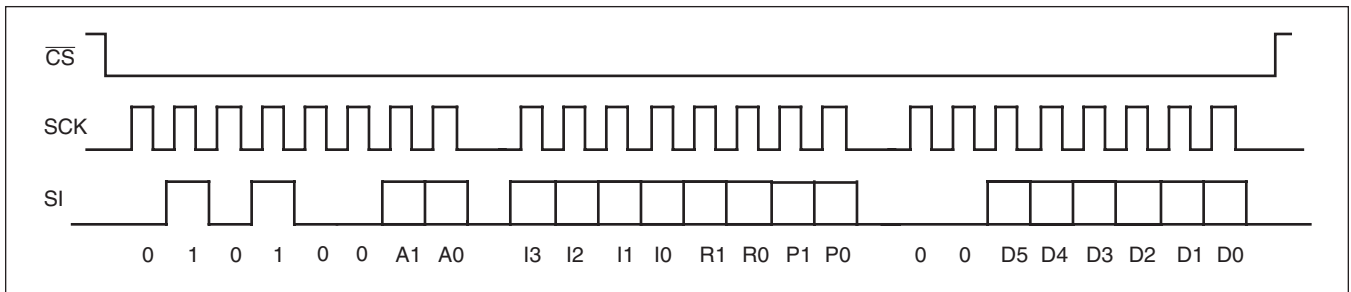

Figure 6. Three-Byte Instruction Sequence (Read)

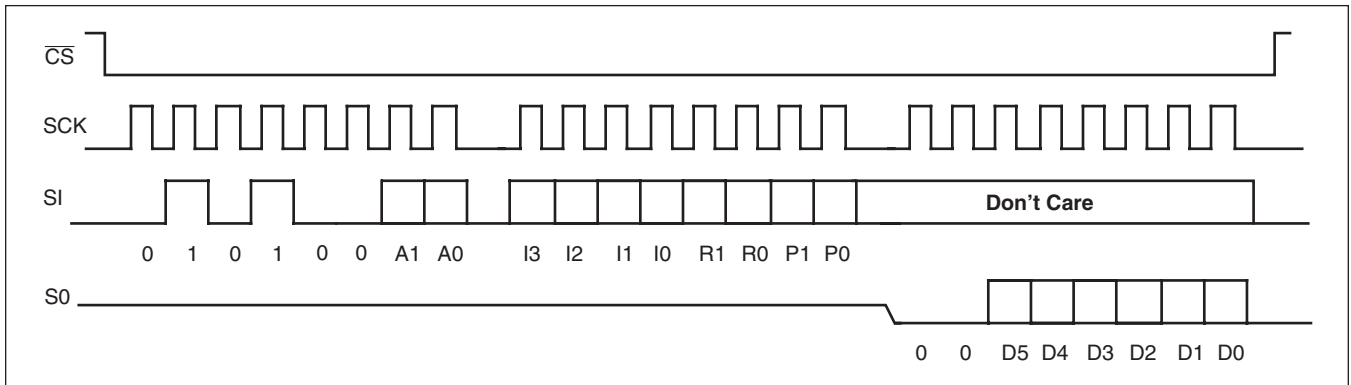

Figure 7. Increment/Decrement Instruction Sequence

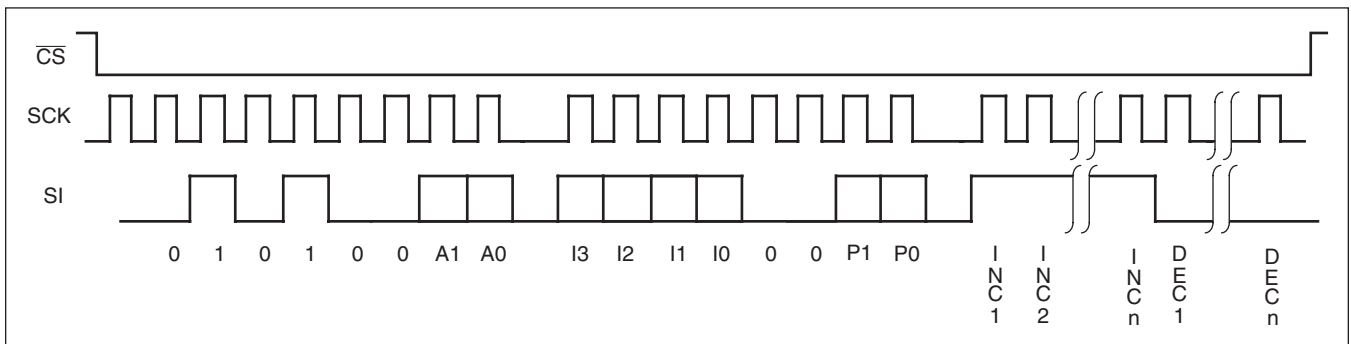

Figure 8. Increment/Decrement Timing Limits

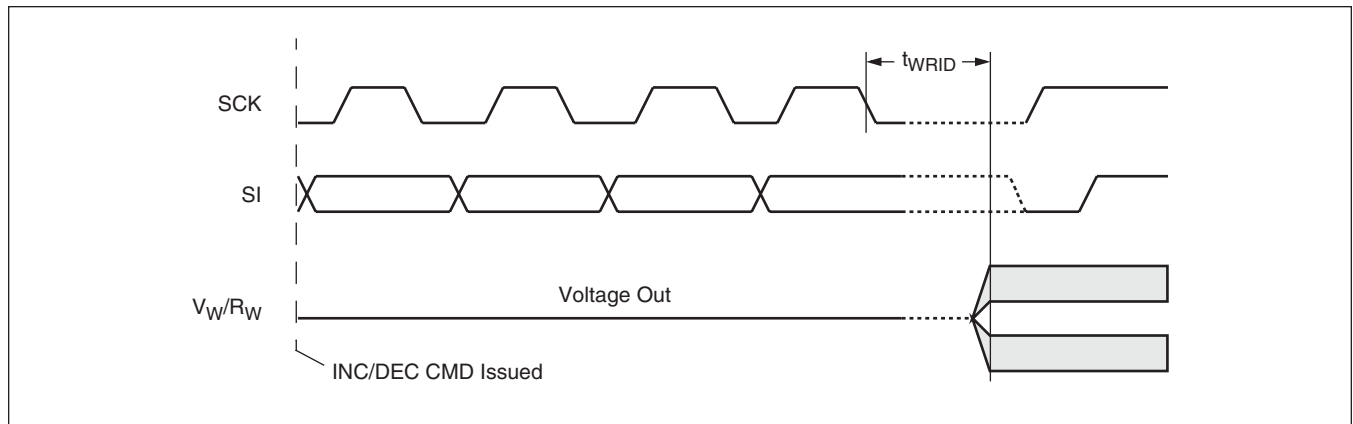

Table 1. Instruction Set

Instruction	Instruction Set								Operation
	I <sub>3</sub>	I <sub>2</sub>	I <sub>1</sub>	I <sub>0</sub>	R <sub>1</sub>	R <sub>0</sub>	P <sub>1</sub>	P <sub>0</sub>	
Read Wiper Counter Register	1	0	0	1	0	0	P <sub>1</sub>	P <sub>0</sub>	Read the contents of the Wiper Counter Register pointed to by P <sub>1</sub> -P <sub>0</sub>
Write Wiper Counter Register	1	0	1	0	0	0	P <sub>1</sub>	P <sub>0</sub>	Write new value to the Wiper Counter Register pointed to by P <sub>1</sub> -P <sub>0</sub>
Read Data Register	1	0	1	1	R <sub>1</sub>	R <sub>0</sub>	P <sub>1</sub>	P <sub>0</sub>	Read the contents of the Data Register pointed to by P <sub>1</sub> -P <sub>0</sub> and R <sub>1</sub> -R <sub>0</sub>
Write Data Register	1	1	0	0	R <sub>1</sub>	R <sub>0</sub>	P <sub>1</sub>	P <sub>0</sub>	Write new value to the Data Register pointed to by P <sub>1</sub> -P <sub>0</sub> and R <sub>1</sub> -R <sub>0</sub>
XFR Data Register to Wiper Counter Register	1	1	0	1	R <sub>1</sub>	R <sub>0</sub>	P <sub>1</sub>	P <sub>0</sub>	Transfer the contents of the Data Register pointed to by R <sub>1</sub> -R <sub>0</sub> to the Wiper Counter Register pointed to by P <sub>1</sub> -P <sub>0</sub>
XFR Wiper Counter Register to Data Register	1	1	1	0	R <sub>1</sub>	R <sub>0</sub>	P <sub>1</sub>	P <sub>0</sub>	Transfer the contents of the Wiper Counter Register pointed to by P <sub>1</sub> -P <sub>0</sub> to the Register pointed to by R <sub>1</sub> -R <sub>0</sub>
Global XFR Data Register to Wiper Counter Register	0	0	0	1	R <sub>1</sub>	R <sub>0</sub>	0	0	Transfer the contents of the Data Registers pointed to by R <sub>1</sub> -R <sub>0</sub> of all four pots to their respective Wiper Counter Register
Global XFR Wiper Counter Register to Data Register	1	0	0	0	R <sub>1</sub>	R <sub>0</sub>	0	0	Transfer the contents of all Wiper Counter Registers to their respective data Registers pointed to by R <sub>1</sub> -R <sub>0</sub> of all four pots
Increment/Decrement Wiper Counter Register	0	0	1	0	0	0	P <sub>1</sub>	P <sub>0</sub>	Enable Increment/decrement of the Wiper Counter Register pointed to by P <sub>1</sub> -P <sub>0</sub>
Read Status (WIP bit)	0	1	0	1	0	0	0	1	Read the status of the internal write cycle, by checking the WIP bit.

# X9400

## Instruction Format

- Notes:** (1) "A1 ~ A0": stands for the device addresses sent by the master.  
 (2) WPx refers to wiper position data in the Counter Register  
 (3) "I": stands for the increment operation, SI held HIGH during active SCK phase (high).  
 (4) "D": stands for the decrement operation, SI held LOW during active SCK phase (high).

### Read Wiper Counter Register (WCR)

$\overline{\text{CS}}$ Falling Edge	device type identifier		device addresses		instruction opcode		WCR addresses		wiper position (sent by X9400 on SO)						$\overline{\text{CS}}$ Rising Edge										
	0	1	0	1	0	0	A 1	A 0	1	0	0	1	0	0		P 1	P 0	0	0	W P 5	W P 4	W P 3	W P 2	W P 1	W P 0

### Write Wiper Counter Register (WCR)

$\overline{\text{CS}}$ Falling Edge	device type identifier		device addresses		instruction opcode		WCR addresses		Data Byte (sent by Host on SI)						$\overline{\text{CS}}$ Rising Edge									
	0	1	0	1	0	0	A 1	A 0	1	0	1	0	0	0		W P 5	W P 4	W P 3	W P 2	W P 1	W P 0			

### Read Data Register (DR)

$\overline{\text{CS}}$ Falling Edge	device type identifier		device addresses		instruction opcode		DR and WCR addresses		Data Byte (sent by X9400 on SO)						$\overline{\text{CS}}$ Rising Edge											
	0	1	0	1	0	0	A 1	A 0	1	0	1	1	R 1	R 0		P 1	P 0	0	0	W P 5	W P 4	W P 3	W P 2	W P 1	W P 0	

### Write Data Register (DR)

$\overline{\text{CS}}$ Falling Edge	device type identifier		device addresses		instruction opcode		DR and WCR addresses		Data Byte (sent by host on SI)						$\overline{\text{CS}}$ Rising Edge	HIGH-VOLTAGE WRITE CYCLE										
	0	1	0	1	0	0	A 1	A 0	1	1	0	0	R 1	R 0			P 1	P 0	0	0	W P 5	W P 4	W P 3	W P 2	W P 1	W P 0

### Transfer Data Register (DR) to Wiper Counter Register (WCR)

$\overline{\text{CS}}$ Falling Edge	device type identifier		device addresses		instruction opcode		DR and WCR addresses		$\overline{\text{CS}}$ Rising Edge						
	0	1	0	1	0	0	A 1	A 0		1	1	0	1	R 1	R 0

### Transfer Wiper Counter Register (WCR) to Data Register (DR)

$\overline{\text{CS}}$ Falling Edge	device type identifier		device addresses		instruction opcode		DR and WCR addresses		$\overline{\text{CS}}$ Rising Edge	HIGH-VOLTAGE WRITE CYCLE					
	0	1	0	1	0	0	A 1	A 0			1	1	1	0	R 1





# X9400

## ABSOLUTE MAXIMUM RATINGS

Temperature under bias..... -65°C to +135°C  
 Storage temperature..... -65°C to +150°C  
 Voltage on SCK, SCL or any address input with respect to  $V_{SS}$  ..... -1V to +7V  
 Voltage on V+ (referenced to  $V_{SS}$ ) ..... 10V  
 Voltage on V- (referenced to  $V_{SS}$ ) ..... -10V  
 (V+) – (V-) ..... 12V  
 Any  $V_H$  ..... V+  
 Any  $V_L$  ..... V-  
 Lead temperature (soldering, 10 seconds) ..... 300°C  
 $I_W$  (10 seconds) ..... ±12mA

## COMMENT

Stresses above those listed under “Absolute Maximum Ratings” may cause permanent damage to the device. This is a stress rating only; functional operation of the device (at these or any other conditions above those listed in the operational sections of this specification) is not implied. Exposure to absolute maximum rating conditions for extended periods may affect device reliability.

## RECOMMENDED OPERATING CONDITIONS

Temperature	Min.	Max.
Commercial	0°C	+70°C
Industrial	-40°C	+85°C

Device	Supply Voltage ( $V_{CC}$ ) Limits
X9400	5V ±10%
X9400-2.7	2.7V to 5.5V

## ANALOG CHARACTERISTICS (Over recommended operating conditions unless otherwise stated.)

Symbol	Parameter	Limits				Test Conditions
		Min.	Typ.	Max.	Unit	
$R_{TOTAL}$	End to end resistance			±20	%	
	Power rating			50	mW	25°C, each pot
$I_W$	Wiper current			±6	mA	
$R_W$	Wiper resistance		150	250	Ω	Wiper Current = ± 1mA, $V_{CC} = 3V$
			40	100	Ω	Wiper Current = ± 1mA, $V_{CC} = 5V$
Vv+	Voltage on V+ Pin	X9400	+4.5	+5.5	V	
		X9400-2.7	+2.7	+5.5		
Vv-	Voltage on V- Pin	X9400	-5.5	-4.5	V	
		X9400-2.7	-5.5	-2.7		
$V_{TERM}$	Voltage on any $V_H/R_H$ or $V_L/R_L$ Pin	V-		V+	V	
	Noise		-120		dBV	Ref: 1kHz
	Resolution		1.6		%	
	Absolute linearity <sup>(1)</sup>	-1		+1	MI <sup>(3)</sup>	$R_{W(n)(actual)} - R_{W(n)(expected)}$
	Relative linearity <sup>(2)</sup>	-0.2		+0.2	MI <sup>(3)</sup>	$R_{W(n+1)} - [R_{W(n)} + MI]$
	Temperature coefficient of $R_{TOTAL}$		±300		ppm/°C	
$C_H/C_L/C_W$	Potentiometer capacitances		10/10/25		pF	See Spice Macromodel
$I_{AL}$	$R_H, R_L, R_W$ leakage current		0.1	10	μA	$V_{IN} = V_{SS}$ to $V_{CC}$ . Device is in stand-by mode.

- Notes:** (1) Absolute linearity is utilized to determine actual wiper voltage versus expected voltage as determined by wiper position when used as a potentiometer.  
 (2) Relative linearity is utilized to determine the actual change in voltage between two successive tap positions when used as a potentiometer. It is a measure of the error in step size.  
 (3) MI =  $RTOT/63$  or  $(R_H - R_L)/63$ , single pot

# X9400

## D.C. OPERATING CHARACTERISTICS (Over the recommended operating conditions unless otherwise specified.)

Symbol	Parameter	Limits				Test Conditions
		Min.	Typ.	Max.	Units	
I <sub>CC1</sub>	V <sub>CC</sub> supply current (Active)			400	μA	f <sub>SCK</sub> = 2MHz, SO = Open, Other Inputs = V <sub>SS</sub>
I <sub>CC2</sub>	V <sub>CC</sub> supply current (Nonvolatile Write)			1	mA	f <sub>SCK</sub> = 2MHz, SO = Open, Other Inputs = V <sub>SS</sub>
I <sub>SB</sub>	V <sub>CC</sub> current (standby)			1	μA	SCK = SI = V <sub>SS</sub> , Addr. = V <sub>SS</sub>
I <sub>LI</sub>	Input leakage current			10	μA	V <sub>IN</sub> = V <sub>SS</sub> to V <sub>CC</sub>
I <sub>LO</sub>	Output leakage current			10	μA	V <sub>OUT</sub> = V <sub>SS</sub> to V <sub>CC</sub>
V <sub>IH</sub>	Input HIGH voltage	V <sub>CC</sub> × 0.7		V <sub>CC</sub> + 0.5	V	
V <sub>IL</sub>	Input LOW voltage	-0.5		V <sub>CC</sub> × 0.1	V	
V <sub>OL</sub>	Output LOW voltage			0.4	V	I <sub>OL</sub> = 3mA

## ENDURANCE AND DATA RETENTION

Parameter	Min.	Unit
Minimum endurance	100,000	Data changes per bit per register
Data retention	100	years

## CAPACITANCE

Symbol	Test	Max.	Unit	Test Conditions
C <sub>OUT</sub> <sup>(4)</sup>	Output capacitance (SO)	8	pF	V <sub>OUT</sub> = 0V
C <sub>IN</sub> <sup>(4)</sup>	Input capacitance (A0, A1, SI, and SCK)	6	pF	V <sub>IN</sub> = 0V

## POWER-UP TIMING

Symbol	Parameter	Min.	Max.	Unit
t <sub>PUR</sub> <sup>(5)</sup>	Power-up to initiation of read operation		1	ms
t <sub>PUW</sub> <sup>(5)</sup>	Power-up to initiation of write operation		5	ms
t <sub>R V<sub>CC</sub></sub> <sup>(4)</sup>	V <sub>CC</sub> Power up ramp	0.2	50	V/msec

**POWER UP REQUIREMENTS** (Power Up sequencing can affect correct recall of the wiper registers)

The preferred power-on sequence is as follows: First V<sub>CC</sub>, then the potentiometer pins, R<sub>H</sub>, R<sub>L</sub>, and R<sub>W</sub>. Voltage should not be applied to the potentiometer pins before V+ or V- is applied. The V<sub>CC</sub> ramp rate specification should be met, and any glitches or slope changes in the V<sub>CC</sub> line should be held to <100mV if possible. If V<sub>CC</sub> powers down, it should be held below 0.1V for more than 1 second before powering up again in order for proper wiper register recall. Also, V<sub>CC</sub> should not reverse polarity by more than 0.5V. Recall of wiper position will not be complete until V<sub>CC</sub>, V+ and V- reach their final value.

## EQUIVALENT A.C. LOAD CIRCUIT

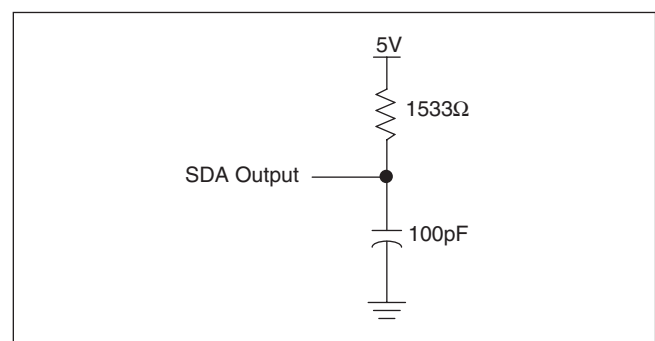

# X9400

## A.C. TEST CONDITIONS

Input pulse levels	$V_{CC} \times 0.1$ to $V_{CC} \times 0.9$
Input rise and fall times	10ns
Input and output timing level	$V_{CC} \times 0.5$

**Notes:** (4) This parameter is periodically sampled and not 100% tested  
 (5)  $t_{PUR}$  and  $t_{PUW}$  are the delays required from the time the third (last) power supply ( $V_{CC}$ ,  $V+$  or  $V-$ ) is stable until the specific instruction can be issued. These parameters are periodically sampled and not 100% tested.

## SPICE Macro Model

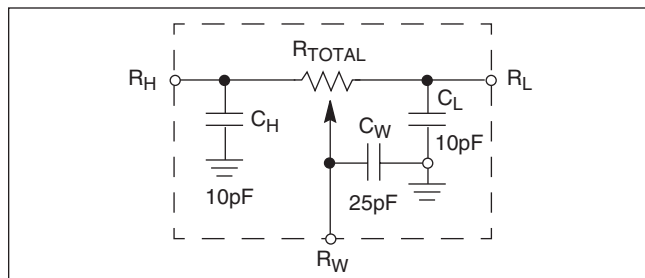

## SYMBOL TABLE

WAVEFORM	INPUTS	OUTPUTS
	Must be steady	Will be steady
	May change from Low to High	Will change from Low to High
	May change from High to Low	Will change from High to Low
	Don't Care: Changes Allowed	Changing: State Not Known
	N/A	Center Line is High Impedance

## AC TIMING

Symbol	Parameter	Min.	Max.	Unit
$f_{SCK}$	SSI/SPI clock frequency		2.0	MHz
$t_{CYC}$	SSI/SPI clock cycle time	500		ns
$t_{WH}$	SSI/SPI clock high time	200		ns
$t_{WL}$	SSI/SPI clock low time	200		ns
$t_{LEAD}$	Lead time	250		ns
$t_{LAG}$	Lag time	250		ns
$t_{SU}$	SI, SCK, $\overline{HOLD}$ and $\overline{CS}$ input setup time	50		ns
$t_H$	SI, SCK, $\overline{HOLD}$ and $\overline{CS}$ input hold time	50		ns
$t_{RI}$	SI, SCK, $\overline{HOLD}$ and $\overline{CS}$ input rise time		2	$\mu s$
$t_{FI}$	SI, SCK, $\overline{HOLD}$ and $\overline{CS}$ input fall time		2	$\mu s$
$t_{DIS}$	SO output disable time	0	500	ns
$t_V$	SO output valid time		100	ns
$t_{HO}$	SO output hold time	0		ns
$t_{RO}$	SO output rise time		50	ns
$t_{FO}$	SO output fall time		50	ns
$t_{HOLD}$	HOLD time	400		ns
$t_{HSU}$	HOLD setup time	100		ns
$t_{HH}$	$\overline{HOLD}$ hold time	100		ns
$t_{HZ}$	$\overline{HOLD}$ low to output in High Z		100	ns
$t_{LZ}$	$\overline{HOLD}$ high to output in Low Z		100	ns
$T_I$	Noise suppression time constant at SI, SCK, $\overline{HOLD}$ and $\overline{CS}$ inputs		20	ns
$t_{CS}$	$\overline{CS}$ deselect time	2		$\mu s$
$t_{WPASU}$	$\overline{WP}$ , A0 and A1 setup time	0		ns
$t_{WPAH}$	$\overline{WP}$ , A0 and A1 hold time	0		ns

# X9400

## HIGH-VOLTAGE WRITE CYCLE TIMING

Symbol	Parameter	Typ.	Max.	Unit
$t_{WR}$	High-voltage write cycle time (store instructions)	5	10	ms

## XDCP TIMING

Symbol	Parameter	Min.	Max.	Unit
$t_{WRPO}$	Wiper response time after the third (last) power supply is stable		10	$\mu$ s
$t_{WRL}$	Wiper response time after instruction issued (all load instructions)		10	$\mu$ s
$t_{WRID}$	Wiper response time from an active SCL/SCK edge (increment/decrement instruction)		450	ns

## TIMING DIAGRAMS

### Input Timing

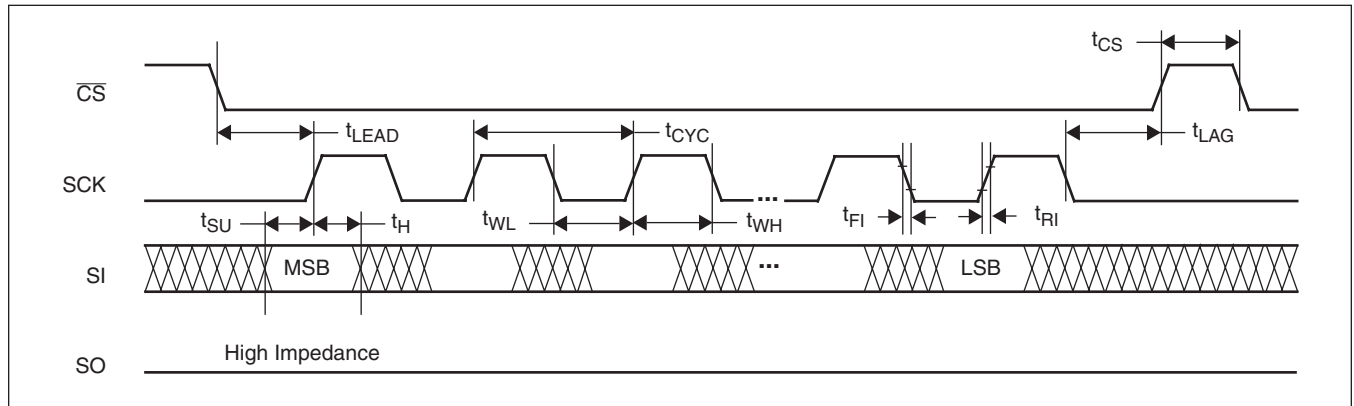

### Output Timing

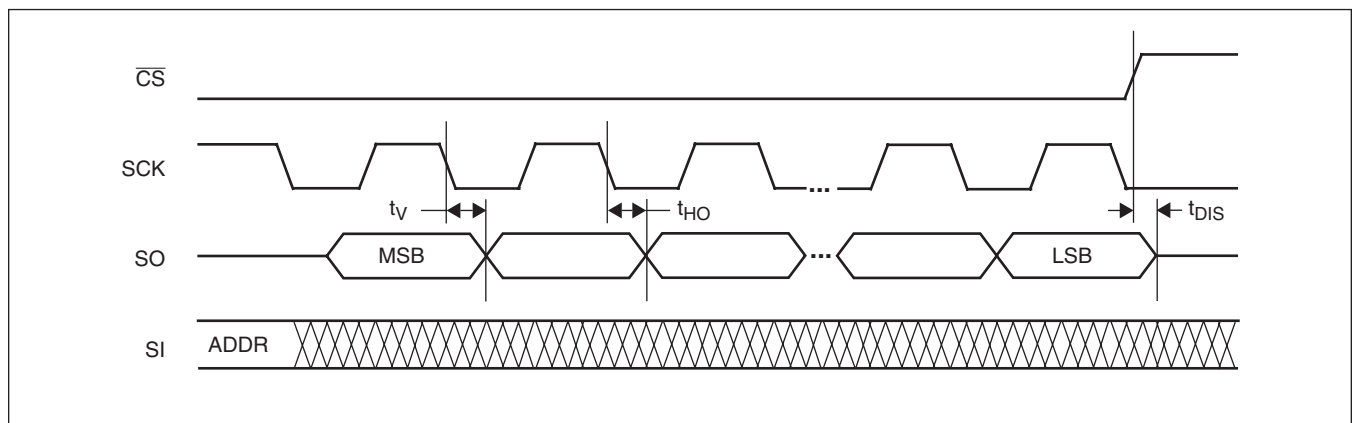

# X9400

## Hold Timing

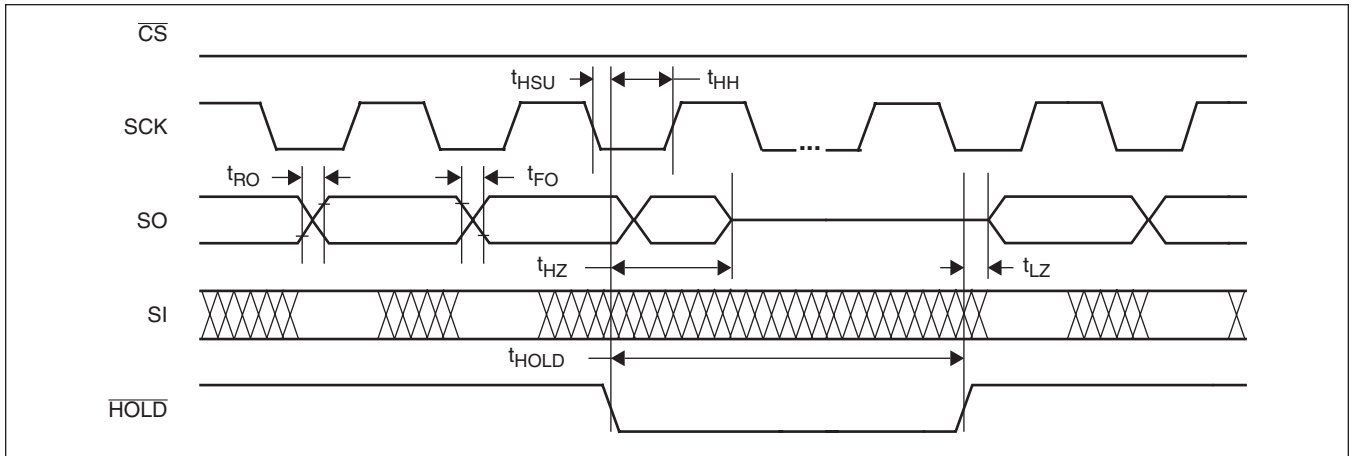

## XDCP Timing (for All Load Instructions)

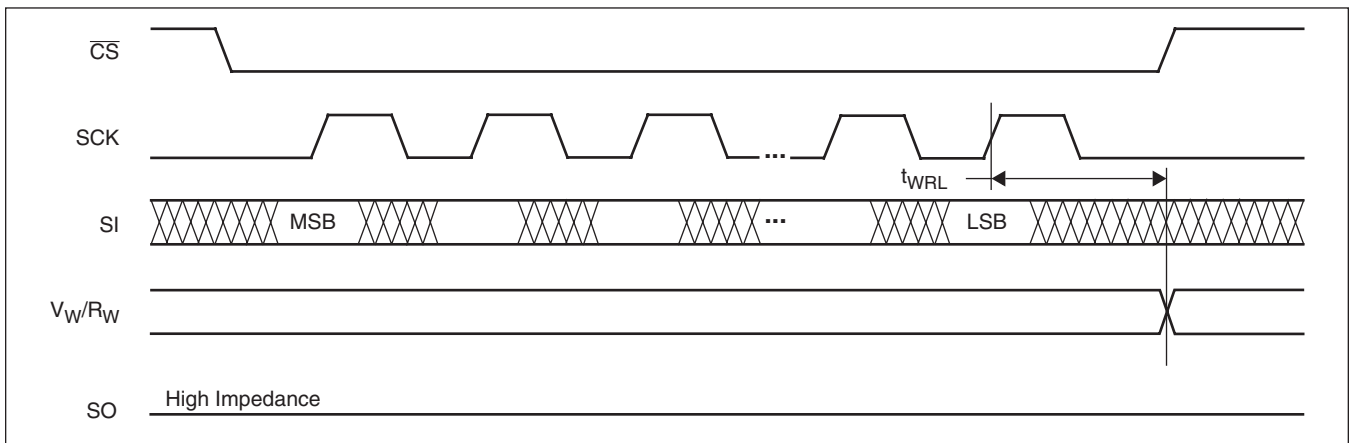

## XDCP Timing (for Increment/Decrement Instruction)

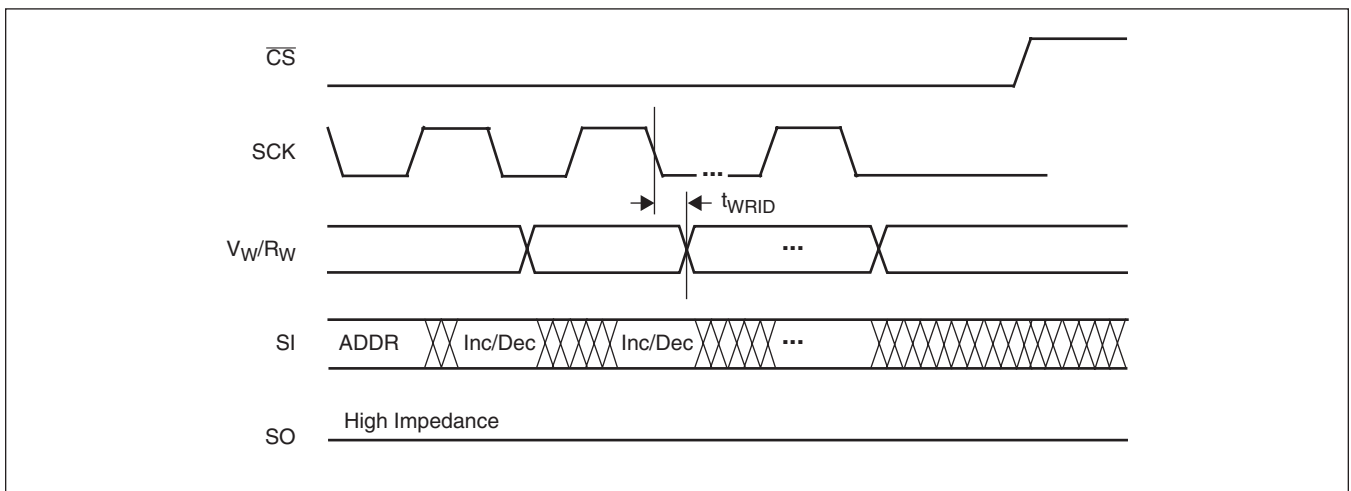

# X9400

## Write Protect and Device Address Pins Timing

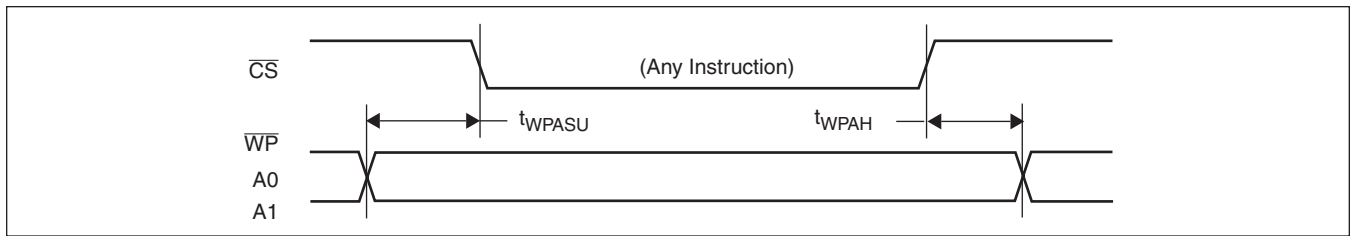

## APPLICATIONS INFORMATION

### Basic Configurations of Electronic Potentiometers

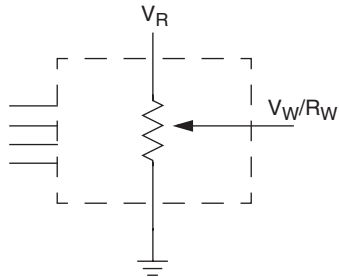

Three terminal Potentiometer;  
Variable voltage divider

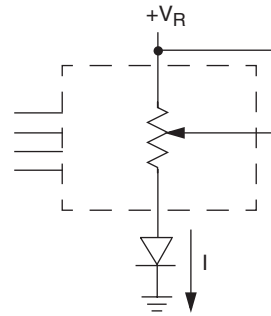

Two terminal Variable Resistor;  
Variable current

### Application Circuits

#### Noninverting Amplifier

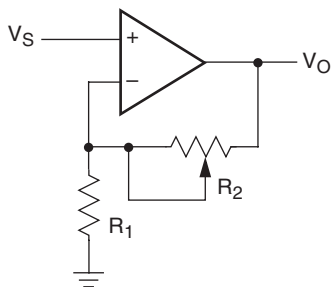

$$V_O = (1 + R_2/R_1)V_S$$

#### Voltage Regulator

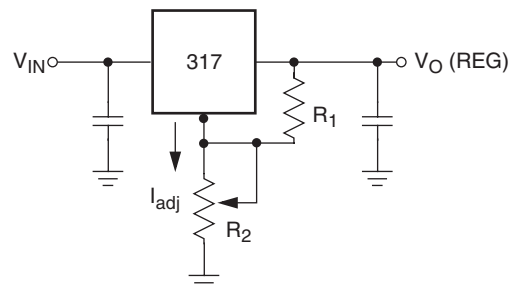

$$V_O (\text{REG}) = 1.25V (1 + R_2/R_1) + I_{\text{adj}} R_2$$

#### Offset Voltage Adjustment

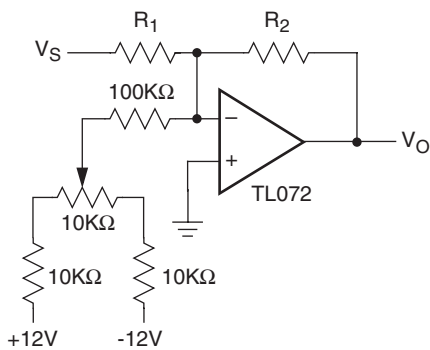

#### Comparator with Hysteresis

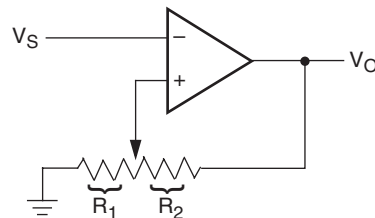

$$V_{UL} = \{R_1/(R_1 + R_2)\} V_O(\text{max})$$

$$V_{LL} = \{R_1/(R_1 + R_2)\} V_O(\text{min})$$



Application Circuits (continued)

Attenuator

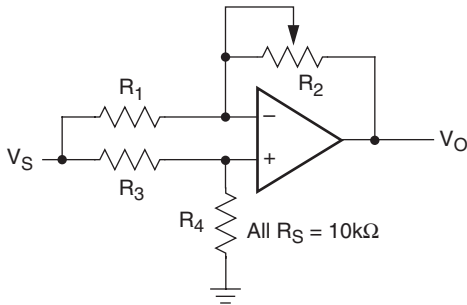

$$V_O = G V_S$$

$$-1/2 \leq G \leq +1/2$$

Filter

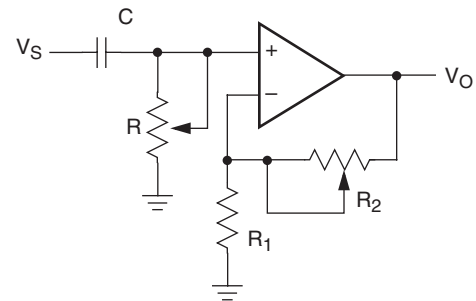

$$G_O = 1 + R_2/R_1$$

$$f_c = 1/(2\pi RC)$$

Inverting Amplifier

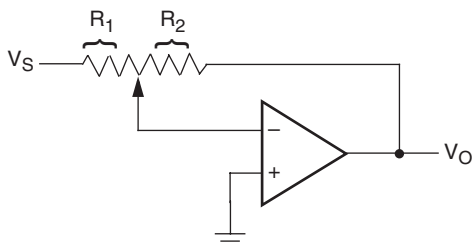

$$V_O = G V_S$$

$$G = -R_2/R_1$$

Equivalent L-R Circuit

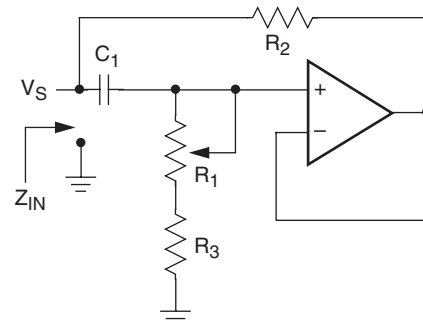

$$Z_{IN} = R_2 + s R_2 (R_1 + R_3) C_1 = R_2 + s L_{eq}$$

$$(R_1 + R_3) \gg R_2$$

Function Generator

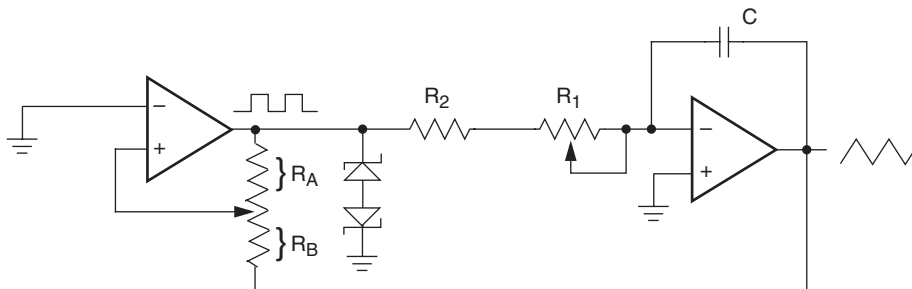

$$\text{frequency} \propto R_1, R_2, C$$

$$\text{amplitude} \propto R_A, R_B$$

PACKAGING INFORMATION

24-Lead Plastic Dual In-Line Package Type P

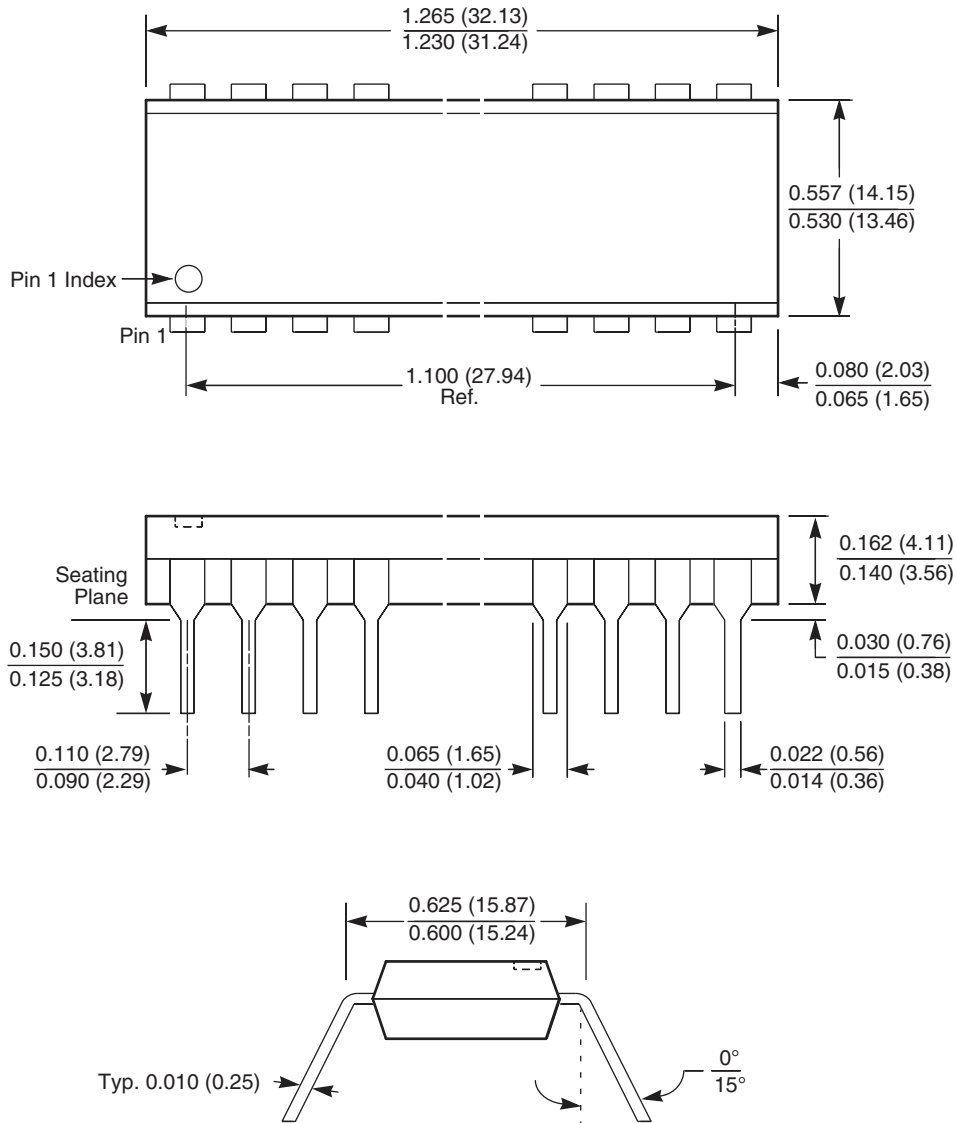

- NOTE:**
1. ALL DIMENSIONS IN INCHES (IN PARENTHESES IN MILLIMETERS)
  2. PACKAGE DIMENSIONS EXCLUDE MOLDING FLASH

**PACKAGING INFORMATION**

**24-Lead Plastic Small Outline Gull Wing Package Type S**

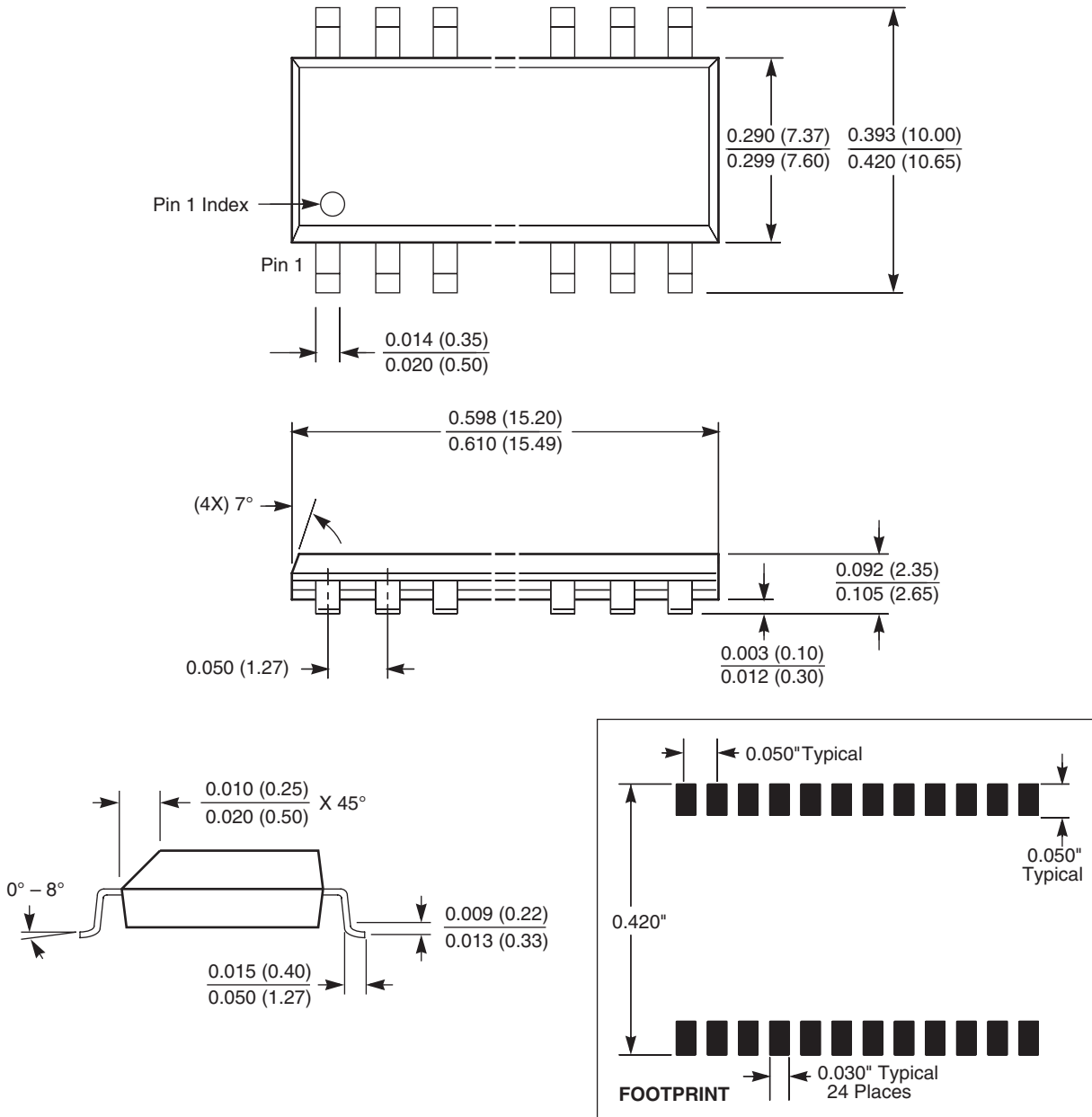

**NOTE: ALL DIMENSIONS IN INCHES (IN PARENTHESES IN MILLIMETERS)**

PACKAGING INFORMATION

24-Lead Plastic, TSSOP Package Type V

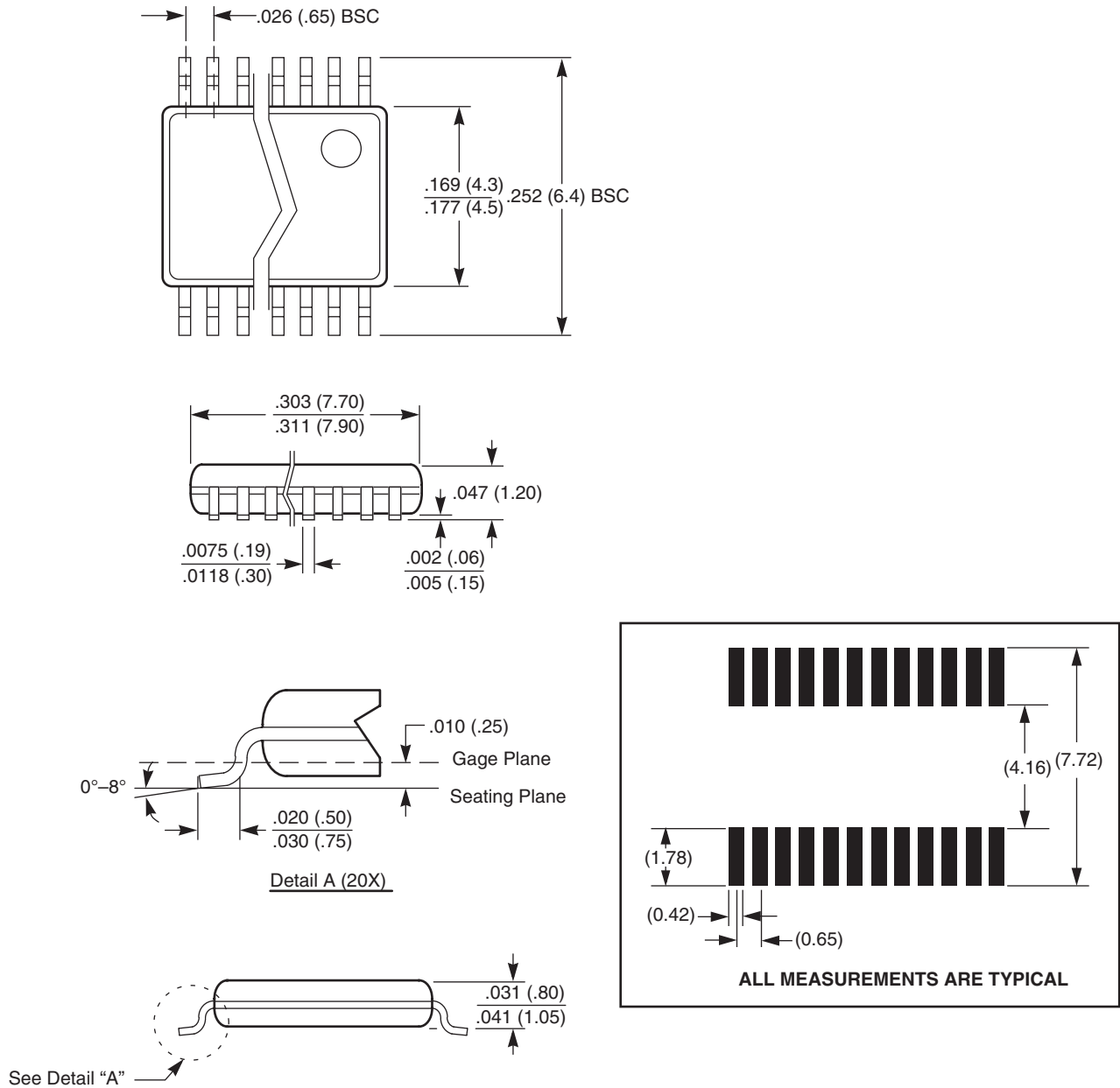

NOTE: ALL DIMENSIONS IN INCHES (IN PARENTHESES IN MILLIMETERS)

PACKAGING INFORMATION

24-Bump Chip Scale Package (CSP B24)  
Package Outline Drawing

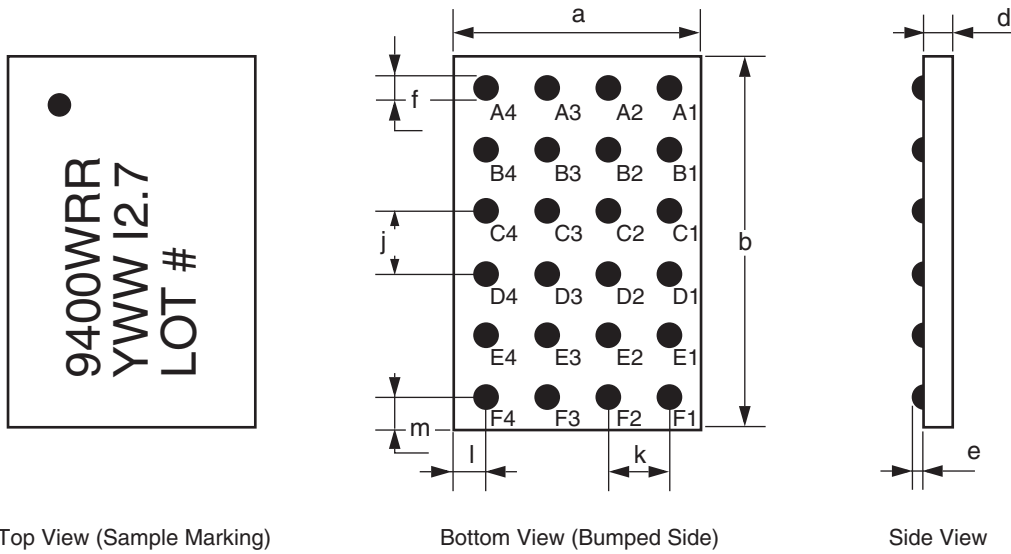

Top View (Sample Marking)

Bottom View (Bumped Side)

Side View

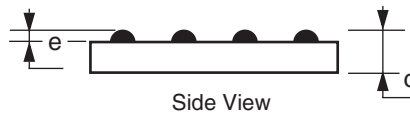

Side View

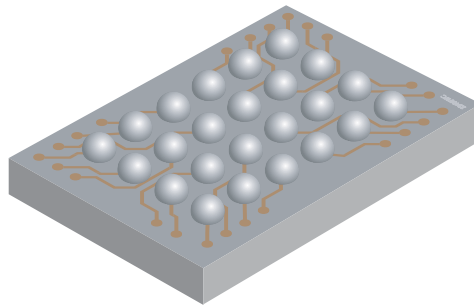

Package Dimensions

	Symbol	Millimeters		
		Min	Nominal	Max
Package Width	a	2.595	2.625	2.655
Package Length	b	3.814	3.844	3.874
Package Height	c	0.644	0.677	0.710
Body Thickness	d	0.444	0.457	0.470
Ball Height	e	0.280	0.300	0.320
Ball Diameter	f	0.350	0.370	0.390
Ball Pitch – Width	j		0.5	
Ball Pitch – Length	k		0.5	
Ball to Edge Spacing – Width	l	0.538	0.563	0.588
Ball to Edge Spacing – Length	m	0.647	0.672	0.697

Ball Matrix

	4	3	2	1
A	RL1	A1	$\overline{CS}$	RW0
B	RW1	SI	$\overline{WP}$	RL0
C	VSS	RH1	RH0	VCC
D	V-	RH2	RH3	V+
E	RW2	$\overline{HOLD}$	SO	RL3
F	RL2	SCK	A0	RW3

# X9400

## Ordering Information

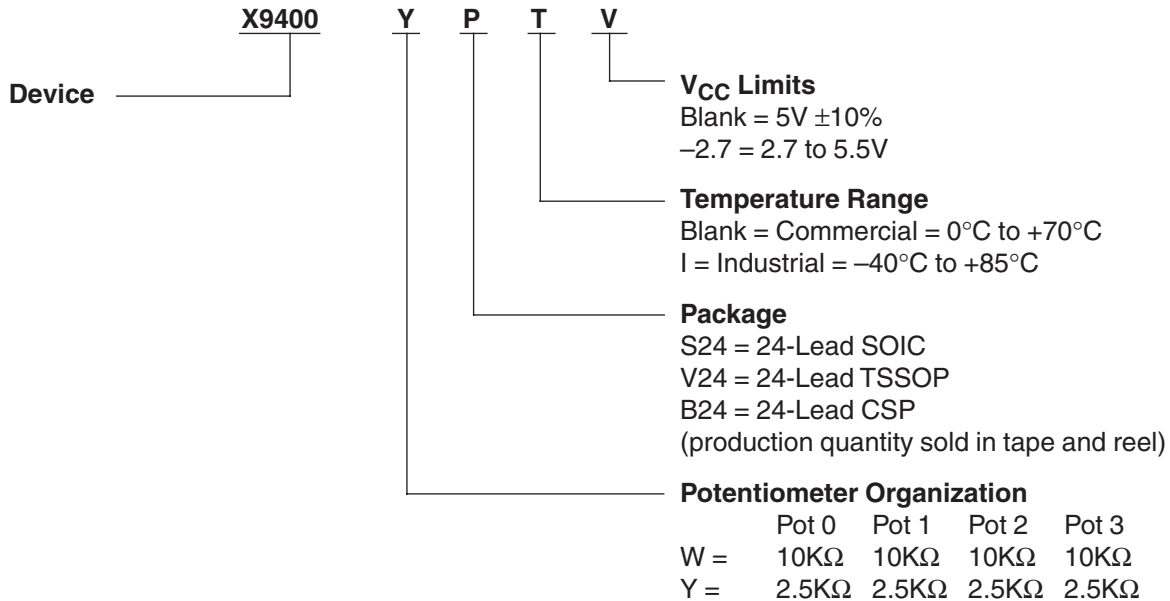

### LIMITED WARRANTY

©Xicor, Inc. 2003 Patents Pending

Devices sold by Xicor, Inc. are covered by the warranty and patent indemnification provisions appearing in its Terms of Sale only. Xicor, Inc. makes no warranty, express, statutory, implied, or by description regarding the information set forth herein or regarding the freedom of the described devices from patent infringement. Xicor, Inc. makes no warranty of merchantability or fitness for any purpose. Xicor, Inc. reserves the right to discontinue production and change specifications and prices at any time and without notice.

Xicor, Inc. assumes no responsibility for the use of any circuitry other than circuitry embodied in a Xicor, Inc. product. No other circuits, patents, or licenses are implied.

### TRADEMARK DISCLAIMER:

Xicor and the Xicor logo are registered trademarks of Xicor, Inc. AutoStore, Direct Write, Block Lock, SerialFlash, MPS, and XDCP are also trademarks of Xicor, Inc. All others belong to their respective owners.

### U.S. PATENTS

Xicor products are covered by one or more of the following U.S. Patents: 4,326,134; 4,393,481; 4,404,475; 4,450,402; 4,486,769; 4,488,060; 4,520,461; 4,533,846; 4,599,706; 4,617,652; 4,668,932; 4,752,912; 4,829,482; 4,874,967; 4,883,976; 4,980,859; 5,012,132; 5,003,197; 5,023,694; 5,084,667; 5,153,880; 5,153,691; 5,161,137; 5,219,774; 5,270,927; 5,324,676; 5,434,396; 5,544,103; 5,587,573; 5,835,409; 5,977,585. Foreign patents and additional patents pending.

### LIFE RELATED POLICY

In situations where semiconductor component failure may endanger life, system designers using this product should design the system with appropriate error detection and correction, redundancy and back-up features to prevent such an occurrence.

Xicor's products are not authorized for use in critical components in life support devices or systems.

1. Life support devices or systems are devices or systems which, (a) are intended for surgical implant into the body, or (b) support or sustain life, and whose failure to perform, when properly used in accordance with instructions for use provided in the labeling, can be reasonably expected to result in a significant injury to the user.
2. A critical component is any component of a life support device or system whose failure to perform can be reasonably expected to cause the failure of the life support device or system, or to affect its safety or effectiveness.